

LUXMAN

OWNER'S MANUAL

T-117

Digital Synthesized AM/FM Stereo Tuner

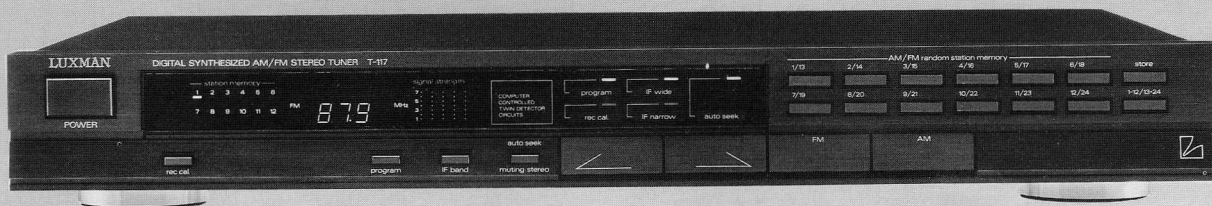

TABLE OF CONTENTS

Introduction.....	3
Safety Instructions.....	4
Special Features.....	5
Controls & Switches — Front Panel.....	6, 7
Jacks & Terminals — Rear Panel.....	7, 8
Connection Diagram.....	9
Connection Guidelines.....	9, 10
Operation Guidelines.....	11, 12
Block Diagram.....	13
Care and Maintenance.....	14
In Case Of Difficulty.....	14
Specifications.....	15

WARNING: To reduce the risk of fire or electric shock, do not expose this appliance to rain or moisture

CAUTION: To prevent electric shock, do not use this (polarized) plug with an extension cord, receptacle or other outlet unless the blades can be fully inserted to prevent blade exposure.



The lightning-flash with arrowhead symbol, within an equilateral triangle, is intended to alert the user to the presence of uninsulated "dangerous voltage" within the product's enclosure that may be of sufficient magnitude to constitute a risk of electric shock to persons.



The exclamation point within an equilateral triangle is intended to alert the user to the presence of important operating instructions in the literature accompanying the appliance.



CAUTION
RISK OF ELECTRIC SHOCK
DO NOT OPEN
CAUTIONS: TO REDUCE THE RISK OF ELECTRIC SHOCK DO NOT REMOVE COVER (OR BACK). NO USER-SERVICEABLE PARTS INSIDE. REFER SERVICING TO QUALIFIED SERVICE PERSONNEL.



INTRODUCTION

WELCOME!

Luxman welcomes you to the growing number of discerning audiophiles who own and operate Luxman Audio and Audio-Video Products. We take great pride in the long tradition of excellence in sonic quality that the Luxman name represents. This manual has been prepared to help you maximize your enjoyment of the outstanding performance and features of your new Luxman T-117.

This high quality AM/FM component tuner employs advanced technological refinements and features to provide near perfect state-of-the-art performance. Twin FM detectors, low noise dual gate MOS-FET 4 varactor front end, 24 FM/AM random station presets, wide/narrow FM bandwidths, C.A.T. (computer analyzed tuning), system remote control capability — are just a few examples.

To realize the exceptional performance for which this tuner is capable, it is necessary that the amplifier and speaker systems used with it are of the highest sonic quality. We recommend complementary Luxman components wherever possible.

Please study this manual carefully and become acquainted with all the special features, operation and capabilities of your new Luxman T-117. Should you have any questions, or desire information on other Luxman products, please contact your local Luxman dealer or call the Luxman customer services department direct at (213) 326-8000.

WHEN YOU OPEN THE BOX

Before any Luxman product leaves the factory it is carefully inspected for physical imperfections as a routine part of Luxman's systematic quality control. This, along with full electrical testing, should insure quality craftsmanship and performance. After you have unpacked the unit, inspect it for any physical damage. Save the shipping carton and all packing materials, as they are essential to reduce to a minimum the possibility of transportation damage, should the product ever need to be shipped again. In the unlikely event that damage has occurred, notify your dealer immediately and request the name of the carrier so that a written claim to cover shipping damages can be initiated.

THE RIGHT TO ANY CLAIM AGAINST A PUBLIC CARRIER CAN BE FORFEITED IF THE CARRIER IS NOT NOTIFIED PROMPTLY AND IF THE SHIPPING CARTON AND PACKING MATERIAL ARE NOT AVAILABLE FOR INSPECTION. SAVE ALL PACKING MATERIALS UNTIL THE CLAIM HAS BEEN SETTLED.

INSTALLATION AND PLACEMENT

The T-117 generates almost no heat, therefore its placement is not critical. However it should not be placed on top of or completely enclosed with high power amplifiers or receivers. If placed in a cabinet with such components, be sure adequate ventilation is provided. With these considerations implemented, the Luxman T-117 should provide exceptional performance in any reasonable environment.

Of course, such normal considerations as protection from excessive dust and moisture should always be observed. The Luxman T-117 tuner has been carefully designed with high quality components so that long term undiminished performance may be expected when it is operated in accordance with the instructions provided.

SAFETY INSTRUCTIONS

1. Read Instructions

All the safety and operating instructions should be read before the unit is operated.

2. Retain Instructions

The safety and operating instructions should be retained for future reference.

3. Heed Warning

All warnings on the unit and in the operating instructions should be adhered to.

4. Follow Instructions

All operating and use instructions should be followed.

5. Water and Moisture

The unit should not be used near water — for example, near a bathtub, washbowl, kitchen sink, laundry tub, in a wet basement, or near a swimming pool, etc.

6. Carts and Stands

The unit should be used only with a cart or stand that is recommended by the manufacturer.

7. Wall or Ceiling Mounting

The unit should be mounted to a wall or ceiling only as recommended by the manufacturer.

8. Ventilation

The unit should be placed where it is well ventilated. The unit should not be placed on a bed, sofa, rugs or similar surface or in an enclosure such as a bookcase or cabinet where there is a little or no ventilation.

9. Heat

The unit should be placed away from heat sources such as radiators, heat registers, stoves, or other appliances (including amplifiers) that produce heat.

10. Power Sources

The unit should be connected to a power supply only of the type described in the operating instructions or as marked on the unit.

11. Grounding or Polarization

Precautions should be taken so that the grounding or polarization means of the unit is not defeated.

12. Power Cord Protection

Power supply cords should be routed so that they are not likely to be walked on or pinched by items placed upon or against them. Pay particular attention to the plug receptacle, and the point where the cord meets the unit.

13. Cleaning

The unit should be cleaned only as recommended by the manufacturer.

14. Power Lines

An outdoor antenna should be located away from power lines.

15. Outdoor Antenna Grounding

If an outdoor antenna is connected to the receiver, be sure the antenna system is grounded so as to provide some protection against voltage surges and built up static charges.

In the U.S.A. section 810 of the National Electrical Code, ANSI/NEPA No. 70-1984, provides information with respect to proper grounding of the mast and supporting structure grounding of the lead-in wire to an antenna discharge unit, size of grounding conductors, location of antenna discharge for the grounding electrode.

- Use No. 10 AWG (5.3mm²) copper wire, No. 8 AWG (8.4mm²) aluminum wire, No. 17 AWG (1.0mm²) copper clad steel wire, bronze wire or larger wire as ground wire.
- Secure antenna lead-in and ground wires to house with stand-off insulators spaced from 4 feet (1.22 meters) to 6 feet (1.83 meters) apart.
- Mount antenna discharge unit as closely as possible to where lead-in enters house.
- Use jumper wire not smaller than No. 6 AWG (13.8mm²) copper or equivalent when separate antenna grounding electrode is used.

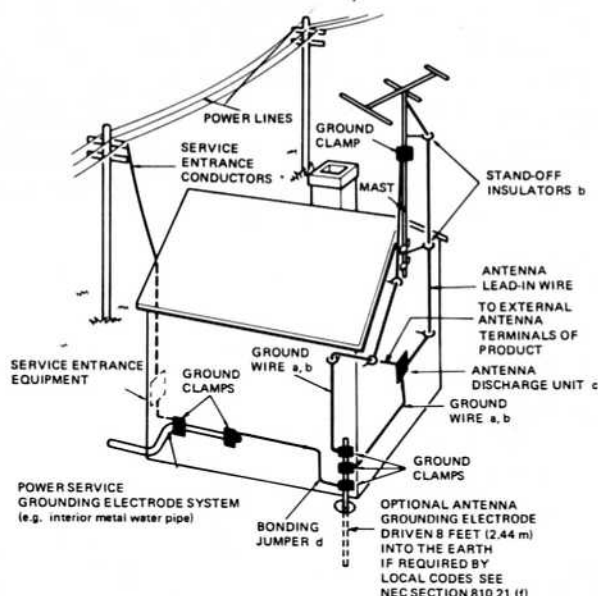

16. Non-use Periods

The power cord of the unit should be unplugged from the outlet when left unused for a long period of time.

17. Object and Liquid Entry

Care should be taken so that objects do not fall and liquids are not spilled into the enclosure through openings.

18. Damage Requiring Service

The unit should be serviced by qualified service personnel when:

- The power-supply cord or the plug has been damaged; or
- Objects have fallen, or liquid has been spilled into the unit; or
- The unit has been exposed to rain; or
- The unit does not appear to operate normally or exhibits a marked change in performance; or
- The unit has been dropped, or the enclosure damaged.

19. Servicing

The user should not attempt to service the unit beyond that described in the operating instructions. All other servicing should be referred to qualified service personnel.

SPECIAL FEATURES

The T-117 employs some of the most refined technology available in high quality component tuners today. Some examples are as follows:

TWIN FM DETECTORS

The T-117 incorporates 2 sophisticated FM detector systems, allowing optimization of signal-to-noise ratio and lowest distortion parameters not possible separately.

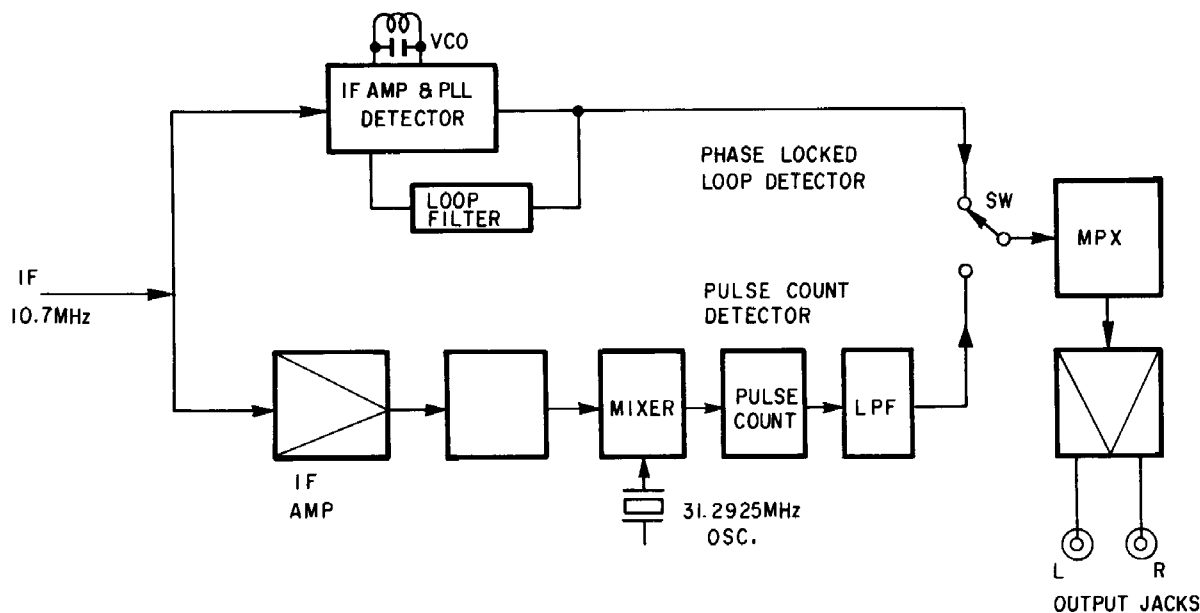

The phase locked loop has superior sensitivity and low noise characteristics, whereas the pulse count detector system excels with highest linearity and lowest THD operation. The PLL operates at low RF levels and the PCD is automatically switched in above 38 dBf, resulting in performance near theoretical limits.

LOW NOISE DUAL GATE MOS-FET VARACTOR FRONT END

A new FM front end design utilizing a low noise dual gate MOS-FET and super linear varactors, combine with the tuner's FM detectors to provide highest possible sensitivity, selectivity and spurious rejection.

24 RANDOM-ACCESS AM/FM STATION MEMORIES

A total of 24 AM and/or FM stations can be memorized in any random pattern. Any station can be instantly recalled by touching the appropriate memory selector button without any need to change the AM or FM tuning selector.

CABLE-READY FM FINE TUNING

Some cable distribution systems providing FM service shift FM station frequencies by 25 or 50 kHz increments to avoid interference with other cable channels. A switch on the rear panel of the T-117 allows this tuner to be precision-tuned to the exact frequencies of these cable-carried stations.

WIDE/NARROW FM BANDWIDTH SELECTION

Helps to eliminate interference in congested signal

areas without compromising lowest possible THD operation under good signal conditions.

C.A.T. (Computer Analyzed Tuning)

Automatically switches to high blend in the 5 to 50 μ V region, mono in the 5 μ V and below region and the TWIN DETECTORS to always provide optimum reception parameters.

SYSTEM REMOTE CONTROL CAPABILITY

Serial Remote IN/OUT rear panel jacks allow connection with other LUXMAN components plus LUXMAN's SYSTEM REMOTE CONTROL CENTERS (U-100, F-105) to provide unified system remote operation.

REC. CAL

Allows accurate and simple off-the-air FM recording.

UNATTENDED PROGRAM RECORDING

With an external timer, the T-117 allows automatic selection of up to 5 stations and/or programs to be sequentially recorded.

CONTROLS & SWITCHES — FRONT PANEL

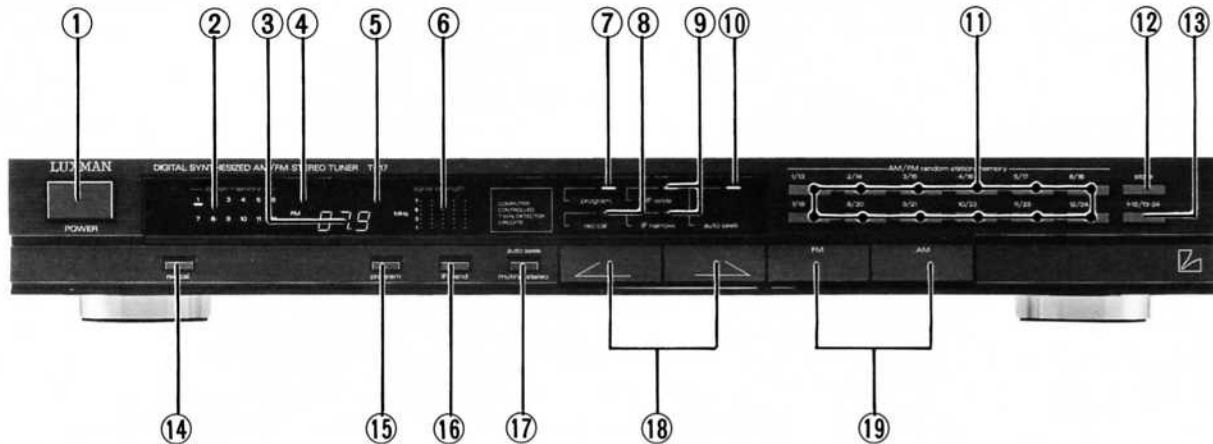

1. POWER Button

Press this button to turn power on and off to the unit.

2. STATION MEMORY Indicators

The station preset number, currently selected from memory, will be indicated by a red bar under or over the corresponding number.

3. DIGITAL DISPLAY

The numeric frequency of the tuned AM or FM station is shown here.

4. STEREO Indicator

Will light up when an FM stereo station is tuned in.

5. MEMORY Indicator

Lights up when the STORE button (item # 12) is pressed.

6. SIGNAL STRENGTH Indicator

Four LED indicator rows will light in an upward direction with increasing strength of FM or AM stations tuned. In addition, the red row will light when precise tuning of the station is accomplished. Be sure this red row lights up when manually tuning with the 25 kHz — 200 kHz switch (item #26, on rear panel) set to the 25 kHz position.

7. PROGRAM Indicator

Lights up when PROGRAM button (item #15) is pressed.

8. REC CAL. Indicator

Lights up when REC CAL button (item #14) is pressed.

9. IF WIDE/NARROW Indicators

These indicate which I.F. bandwidth has been selected by the IF BAND button.

10. AUTO SEEK Indicator

Will light up to show that AUTO SEEK mode has been selected (see item #17).

11. AM/FM RANDOM STATION MEMORY Button

A total of 24 AM and/or FM stations may be placed into memory in any random order and recalled for instant listening, with these buttons. They work in conjunction with the STORE button (item #12) and the 1-12/13-24 button (item #13).

12. STORE Button

Depressing this button will allow any tuned FM or AM station to be stored in any one of the 24 AM/FM RANDOM STATION MEMORY locations (see also item #11). The MEMORY indicator will light when STORE is depressed.

13. 1 — 12/13 — 24 Button

Selects between two sets of 12 station memories provided by the dual function AM/FM RANDOM STATION MEMORY buttons. Selection of stations 1 through 12 or 13 through 24 are shown by the STATION MEMORY indicators (item #2).

CONTROLS & SWITCHES — FRONT PANEL

14. REC CAL

Press to provide a calibrated reference output level when recording FM program material. The 400 Hz output tone will stay on for approx. 8 seconds. See OPERATION GUIDELINES, page 12, for more details.

15. PROGRAM Button

When pressed, the tuner is set up to receive the first 5 stations in memory, sequentially, each time the AC power is turned ON and OFF by an external timer. This allows unattended recording of up to 5 different programs or stations on a connected tape recorder. See OPERATION GUIDELINES for details.

16. IF BAND (wide/narrow) Button

This function allows two choices of FM I.F. tuning selectivity. The IF NARROW position provides increased selectivity and should be used in congested signal areas, as needed, to reduce interference. Use the IF WIDE position, when interference is not noticeable, for highest quality reproduction.

17. AUTO SEEK/MUTING STEREO Button

When depressed, this button activates the AUTO SEEK automatic tuning mode, in conjunction with the TUNING buttons (item #18), for both AM and FM operation. In addition, weak FM stations will be muted and the unit will be placed in the FM STEREO mode. The AUTO SEEK indicator (item #10) will light and the STEREO indicator (item #4) will also light if tuned to an FM stereo station.

When depressed a 2nd time (AUTO SEEK indicator OFF), manual tuning is activated, muting is removed, and the tuner is returned to MONO operation.

18. TUNING UP/DOWN Buttons (← →)

Provides manual Up or Down tuning and initiates auto tuning in the AUTO SEEK mode (item #17) for both FM and AM operation.

19. FM/AM Buttons

Selects FM or AM operation for both AUTO SEEK and MANUAL tuning modes.

JACKS & TERMINALS — REAR PANEL

20. AM LOOP ANTENNA

This antenna can be rotated on its holder (item #21) for maximum pick-up, or removed and placed elsewhere for best reception (within the limitation of its 23" lead length).

21. HOLDER - AM ANTENNA

This holder is designed for easy mounting or removal of the AM LOOP ANTENNA. Align mating surfaces carefully and install with a firm push.

22. 75 OHM FM ANT. "F" Connector

For connection of 75 ohm co-ax cable lead-in with "F" connector, or a 300 ohm lead-in used with the 300-to-75 ohm adapter supplied. See diagram below.

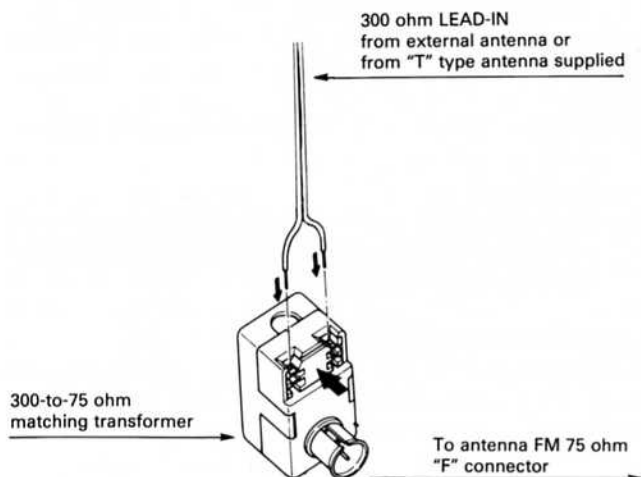

See also "CONNECTION DIAGRAM" page 9.

JACKS & TERMINALS — REAR PANEL

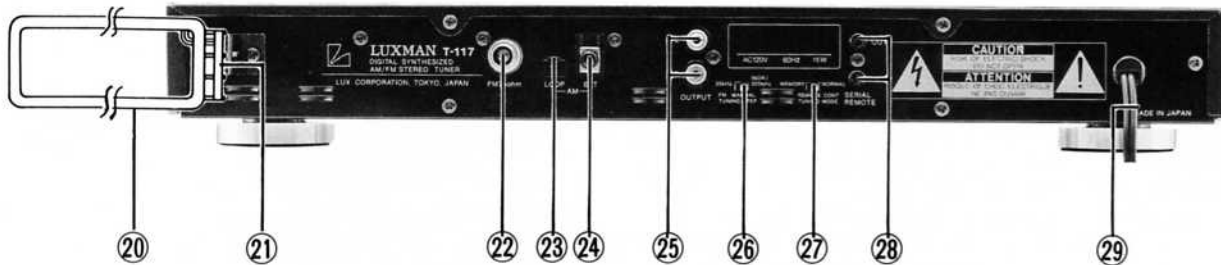

23. AM LOOP ANTENNA Jack

Insert the plug end of the AM LOOP ANTENNA lead into this jack. Be sure to orient and line up to slot correctly. The AM LOOP antenna must be left plugged in (item #23).

24. AM EXT. ANTENNA Terminal

For connection of a long wire AM antenna for fringe area reception.

25. OUTPUT Jacks

For connection to the TUNER inputs of any amplifier or receiver. The output level is 0.55 volts referenced to 100% FM modulation.

26. 25 kHz — 200 kHz TUNING INCREMENT Switch

Some cable systems require 25 kHz tuning increments on FM. Consult your cable company. If required, the T-117 can be set to this increment by placing this switch in the 25 kHz position. See also item #6 and OPERATION GUIDELINES page 11.

27. MEMORY/NORMAL Switch

This switch sets the remote control tuning mode when the T-117 is used with LUXMAN System Remote Control Centers, such as the U-100 and F-105. When placed in the MEMORY position, the T-117 can be tuned to each of the 24 AM and/or FM stations placed in MEMORY (item #11) when the tuning buttons on the remote control are activated.

When placed in the NORMAL position, the T-117 can be tuned across the entire FM or AM bands. In this case tuning is automatically switched to and operates in the AUTO SEEK mode.

28. SERIAL REMOTE IN/OUT Jacks

Use these jacks for a simple and convenient connection of other Luxman components for Remote Control operation. Connect the Serial Remote In and Out jacks to the Serial Remote Out and In jacks, respectively, on other Luxman components (in daisy chain fashion), for a unified remote control system.

NOTE: Turn the power off before connecting these jacks.

29. AC POWER CORD

Insert the polarized AC plug of the T-117 into any 120 volt AC, 50 — 60 Hz wall outlet, or, preferably, into the switched outlet of the amplifier or receiver used with it.

CONNECTION DIAGRAM

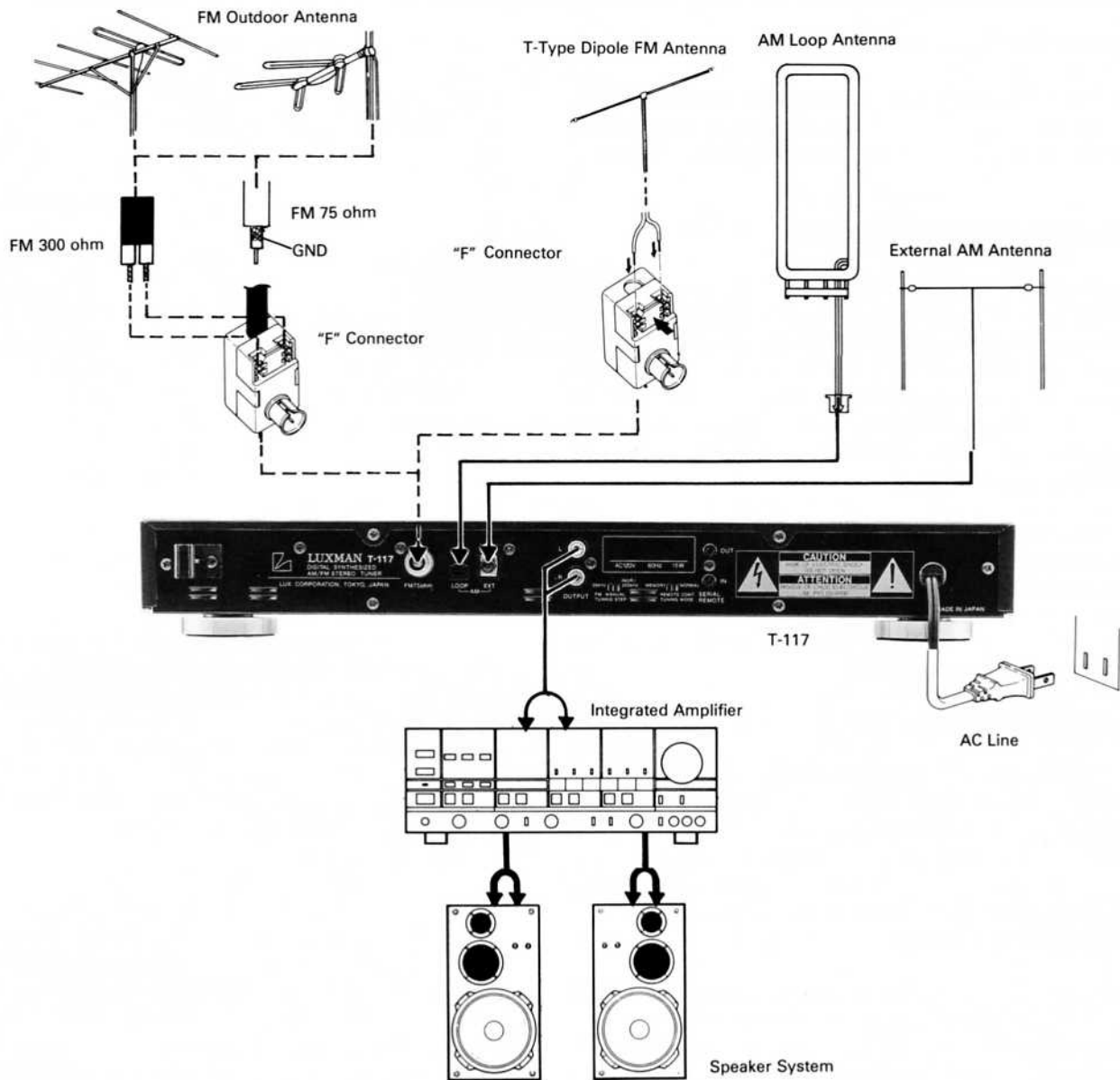

CONNECTION GUIDELINES

BEFORE MAKING CONNECTIONS

It is always wise to ensure that all AC line cords of the various components that you are interconnecting are unplugged from the wall outlets during the hook-up process. This will prevent any inadvertent damage to your speakers or amplifier from incorrect control settings or connections.

INTERCONNECTING LEADS (Patch Cords)

Be sure that left and right channel identification is correct when making interconnections. Most patch cords are color coded with Red ends for the right channel and Black or White ends for the left channel, to make this job easier.

In addition, audio jacks on Luxman equipment, including the T-117, have red centers for right channel and white for left channel.

When making connections, follow the connection diagram above, referring also to the descriptions for items 20 through 29 on page 8.

CONNECTION GUIDELINES

AM ANTENNA

An AM LOOP ANTENNA comes packed with your T-117. Carefully unwrap and mount to back panel and connect leads referring to item #20, 21 on page 7 and 23 on page 8.

FM ANTENNA CONNECTIONS

Included also with your T-117, is a T-type di-pole FM antenna. This type of antenna is simple and practical and will give adequate results in primary signal areas. To use it, unfold it into a "T" shape and connect its leads to the adapter, item #22 and plug into "F" connector on the back of the tuner (See page 10). The antenna is designed to operate in a horizontal position, and may be attached to a nearby wall.

As shown on page 9, the T-117 is also capable of accommodating other types of cable, including 75 Ohm coaxial cable (with or without "F" connector), and 300 Ohm shielded transmission line. These types of cable are for use with outdoor antennas, which will be discussed next.

OUTDOOR FM ANTENNA

As stated before, the supplied folded dipole antenna will give satisfactory results in primary signal areas. However, if you are located in a fringe area where signals are weak, then an outdoor antenna will be necessary. Even if you live in a strong signal location, an outdoor directional antenna may be needed to eliminate "multipath" reflections.

Multipath reflections are responsible for much of the distortion and noise associated with poor FM reception.

They occur when radio waves from the transmitter bounce off of nearby mountains and tall buildings. The reflected waves follow different, more roundabout paths to your tuner and arrive slightly delayed and out of phase with the direct signal (hence, the term "multipath"). This causes distortion in the same manner that "ghost" images are generated on television.

The way to minimize multipath is to use a "beam type" antenna that can be aimed toward the FM transmitter and away from the multipath reflections. The best types of antennas to use are either a "Yagi" or "Log-Periodic" configuration with six or more elements designed expressly for FM reception.

If you want to receive stations from more than one general direction, then you will need a good quality antenna rotor system. This will enable you to point the antenna in the direction giving the least multipath interference, by means of a control box located near the tuner.

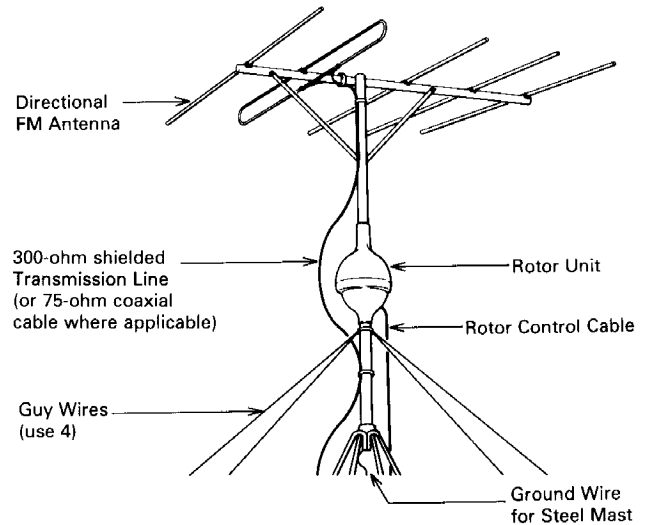

Another important factor is the type of lead-in wire to use. Unshielded lead-in wires, such as 300-ohm twin lead, can act as an omnidirectional antenna, and can cancel the directional benefits of your antenna. Therefore, we recommend using a balanced, shielded 300-ohm cable or a coaxial 75-ohm cable with a 300-to-75 ohm matching transformer at the antenna. These types of shielded cable effectively prevent the lead-in from contributing to multipath distortion.

If you decide to use 75-ohm coaxial cable, we recommend buying cable with "F" type connectors attached. These will fit both the matching transformer and the terminal on the T-117 (See page 7 and 9).

It is considered good practice to connect the antenna mast to an earth ground, both for reasons of safety and noise reduction. If 300-ohm shielded cable is used, connect the shield to ground (GND) at the tuner end only (See page 9).

For rural areas, it is recommended to consult a local dealer about installation and lightning arrestor protection.

We don't recommend using master antenna systems, such as those found in apartment buildings. Such systems are usually designed expressly for television reception and frequently suppress or reduce the quality of the FM signals before distribution.

OPERATION GUIDELINES

AM/FM TUNER OPERATIONS

The T-117 incorporates several tuning methods to provide easy, yet great flexibility in station selection and use. Proceed as follows:

MANUAL TUNING

- (1) Depress AM or FM input selector button as desired.
- (2) Depress AUTO SEEK button to ensure that AUTO SEEK indicator (item #10) is OFF.
- (3) Depress the up → down ← TUNING buttons as required to tune the desired station.

NOTE: These buttons can be pressed in one step increments for fine tuning or held down continuously for rapid tuning.

- (4) On FM, when the desired station is tuned, depress the AUTO SEEK button once again for STEREO operation.

AUTO SEEK TUNING

- (1) Depress AM or FM input selector button as desired.
- (2) Depress AUTO SEEK button to ensure that AUTO SEEK indicator (item #10) is ON.
- (3) Depress the TUNING button in the direction desired to initiate auto seek tuning.
- (4) The receiver will now tune automatically in 10 kHz increments on AM and *200 kHz increments on FM, until a station is found.

NOTE: Due to interfering signals in some areas, it may be found that the tuner will stop at some points off station. If this occurs, simply activate AUTO SEEK again with the TUNING button.

* 25 kHz — 200 kHz TUNING INCREMENT SWITCH (item #26)

When connected to some cable systems, it may be found that correct center-of-channel tuning cannot be obtained. This is because some cable companies shift FM carriers by smaller than the normal 200 kHz odd frequency spacings to avoid interference, etc. Consult your cable company.

If this is the case in your area, simply place this rear panel switch (item #26) in the 25 kHz position. Then, in the manual tuning mode, you can tune in 25 kHz increments for exact tuning. The numbers 25, 50 and 75 (kHz) will appear just to the right of the digital frequency display

(item #3). Step through these frequencies slowly until the red row in the signal strength display (item #6) lights up, indicating precise tuning.

The station can now be stored in MEMORY for instant future recall.

STATION MEMORY OPERATIONS

A total of 24 stations, in any combination of AM and FM stations, and in any random order, may be stored in the tuner's AM/FM RANDOM STATION MEMORY system.

STORE PROCEDURE

- 1) Select AM or FM as desired.
- 2) Tune desired stations using either MANUAL or AUTO SEEK tuning mode.
- 3) Press the 1 — 12/13 — 24 button to choose memory locations 1 through 12 or 13 through 24 as desired.
- 4) Press the STORE button followed immediately by an AM/FM RANDOM STATION MEMORY button of your choice. Repeat for each station, AM or FM that you wish to store.
- 5) Each time STORE is pressed, the MEMORY indicator (item #5) will light for 5 seconds or until a MEMORY button is depressed.
- 6) Each time a MEMORY button is depressed, a corresponding memory indicator item #2 will light.
- 7) To replace a station already in memory, simply tune the new desired station and repeat the above procedure.

STATION RECALL

Stations stored can be played (recalled) instantly by pressing any MEMORY button, selecting locations 1 through 12 and 13 through 24 with the 1 — 12/13 — 24 button.

OPERATION GUIDELINES

TAPE RECORDING FM PROGRAMS

The REC CAL button (item #14) on the T-117, provides a rapid, yet accurate method for setting record level when recording FM program material. Proceed as follows:

- 1) Press the REC CAL button (REC CAL. indicator will light).
- 2) Place connected tape recorder in the RECORD mode.
- 3) Adjust RECORD LEVEL controls of the recorder until the RECORD LEVEL METERS read 0 dB (or 0 VU) in each channel.
- 4) Press REC CAL. button again (REC CAL. indicator OFF) and proceed with recording.

NOTE: The 400 Hz REC CAL. tone will stay on for approx. 8 seconds. If you need more time to make the setting, simply press the button again.

- 5) Mark or otherwise retain this setting of the RECORD LEVEL controls on your tape recorder for all subsequent recordings from FM.

The 400 Hz tone represents full 100% modulation level on FM. It therefore accurately represents the maximum levels of the FM program material, thereby eliminating the tedious record level-setting procedures.

UNATTENDED RECORDING

By use of the PROGRAM BUTTON (item #15) and an external timer it is possible to record up to 5 different programs and/or stations, over a period of time as determined by the timer. Proceed as follows:

- 1) Connect AC lines of the T-117 tuner, your amplifier and tape recorder to the timer AC outlets.
- 2) Set timer to the times of day and days for the broadcasts (AM or FM) you wish to record.
- 3) Store the stations you wish to record, sequentially, in the first 5 STATION MEMORY presets (item #11) on the T-117. (You may store the same station in more than one preset if you wish to record that same station again at a later time.)
- 4) Press PROGRAM button (PROGRAM indicator, item #7, will light) and press Power button (item #1) off.
- 5) Place tape recorder in RECORD mode, having first set recording levels (above) and place its TIMER switch in the RECORD position.
- 6) Place amplifier's POWER switch ON and turn TIMER ON. As the timer turns the system on and off, the T-117 will automatically change from preset #1 through to preset #5, in sequence, repeating the entire sequence after the 5th interval.

BLOCK DIAGRAM

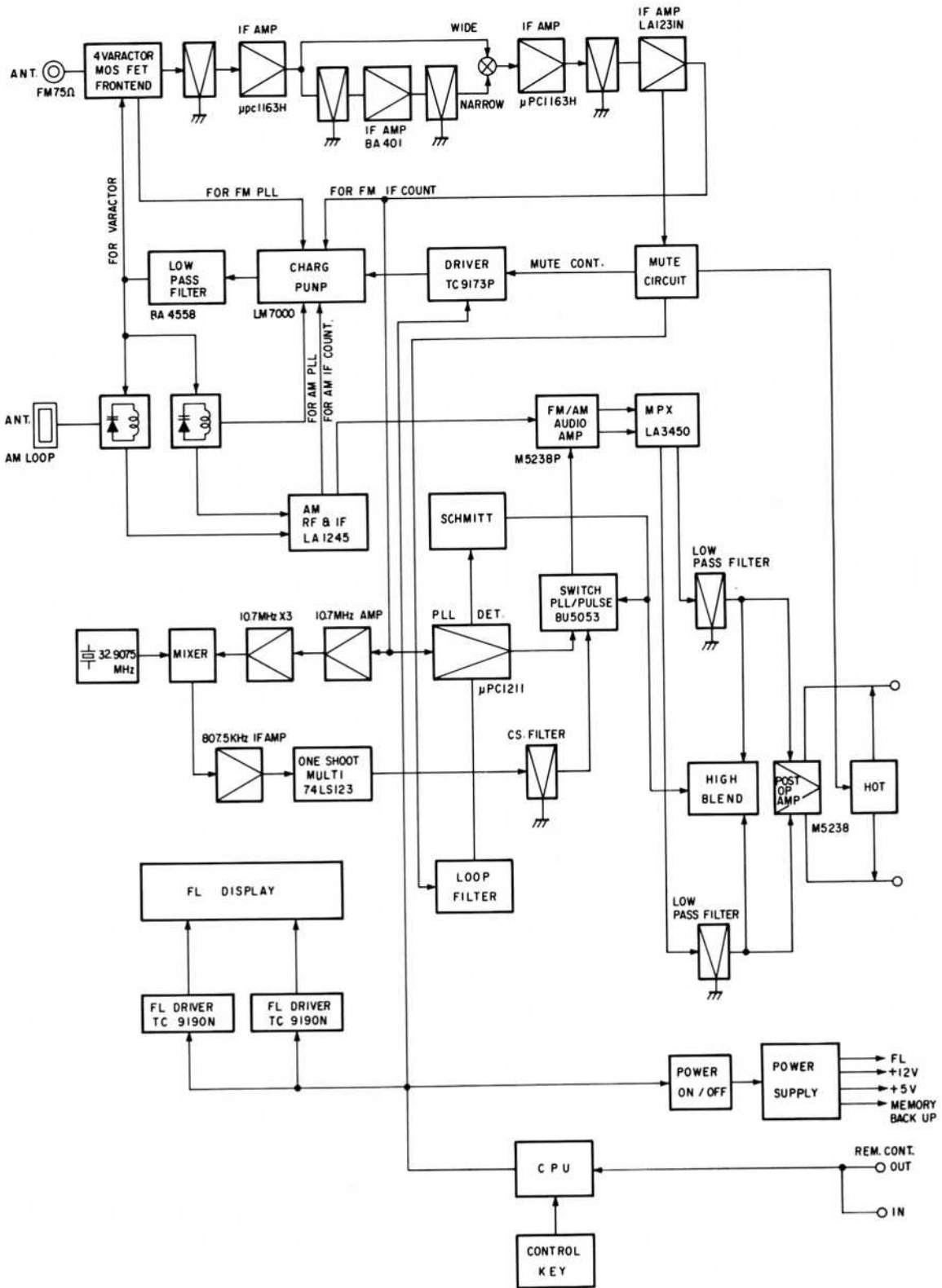

CARE AND MAINTENANCE

CLEANING

The durable finish of the knobs and heavy aluminum front panel will last indefinitely with proper care and cleaning. Never use scouring pads, steel wool, scouring powders, or harsh chemical agents, such as lye solution. These will mar the finish. Clean with a soft, lint-free cloth or cotton swab slightly dampened with a mild solution of detergent and water.

REPACKING FOR SHIPMENT

Should it become necessary to ship your T-117 for any reason, use the original packing materials. If these are no longer available, be sure that adequate materials, at least equivalent to the original, are used.

REPAIRS

Only the most competent and qualified service technicians should be allowed to service the T-117. The Luxman company and its factory-trained warranty station personnel have the knowledge and special equipment needed for repair and calibration of this precision instrument.

In the event of difficulty, call the toll free telephone number listed on the Warranty to obtain the name and address of the Luxman Authorized Service Station nearest your home or business. In many cases, the dealer where you purchased your Luxman unit will be equipped to provide service.

IN CASE OF DIFFICULTY

If you encounter a problem, please review the items in the following checklist. Also, be sure to thoroughly

check other connected components, such as amplifier, speakers, equalizer, etc.

PROBLEM	PROBABLE CAUSE AND SOLUTION
Power Does Not Come On.	<ul style="list-style-type: none"> ● Check line cord to ensure good connection at AC outlet.
No Sound on Tuner.	<ul style="list-style-type: none"> ● FM or AM Antennas not connected or defective cable leads. ● AUTO SEEK MUTING STEREO is on in a weak signal area. Improve antenna and/or place AUTO SEEK in OFF mono mode.
Some FM stations Do Not Tune on Cable System.	<ul style="list-style-type: none"> ● Set switch on rear panel (see item #26) to the 25 kHz incremental tuning position.
FM Sounds Distorted. FM Interference	<ul style="list-style-type: none"> ● Rotate FM antenna, both indoor and outdoor types for cleanest sound (lowest multi-path interference). ● Select IF NARROW (item #16). ● Use outdoor FM antenna if in weak reception area (see page 10).
AM Reception Poor.	<ul style="list-style-type: none"> ● Rotate AM Loop Antenna on back panel for best pick-up. ● If necessary, remove Loop Antenna from rear mount and try a different location (within limits of 23" lead length). ● Determine if other appliances, TVs, fluorescent lights, CDs, computers, etc. are causing interference.

SPECIFICATIONS

FM TUNER SECTION

Receiving Frequency Range... 87.9 MHz — 107.9 MHz
Usable Sensitivity/75 Ω 8.8 dBf
50 dB Quieting Sensitivity/75 Ω :
 Mono 19 dBf
 Stereo 38 dBf
Distortion at 65 dB:
 Mono: 100 Hz/1 kHz 0.04%/0.04%
 : 50 Hz — 10 kHz 0.09%
 Stereo: 100 Hz/1 kHz 0.05%/0.05%
 : 50 Hz — 10 kHz 0.1%
Signal to Noise Ratio at 65 dBf:
 Mono 88 dB
 Stereo 78 dB
Frequency Response..... 20 Hz — 15 kHz (\pm 1.0 dB)
Capture Ratio at 65 dBf: WIDE 1.0 dB
ACS (alternate Chan. Sel.):
 75 kHz Dev. Wide/Narrow 45 dB/80 dB
 (\pm 400 kHz)
 40 kHz Dev. Wide/Narrow 38 dB/70 dB
 (\pm 300 kHz)
Adjacent channel selectivity Narrow: 20 dB
 (\pm 200 kHz)
Image Response Ratio 80 dB
IF Response Ratio 110 dB
Spurious Response Ratio 105 dB
AM Suppression Ratio 70 dB

Sub carrier suppression ratio 60 dB
Stereo Separation(100 Hz/1 kHz) 48 dB/58 dB
Output level/Impedance 700mV/2K Ω

AM TUNER SECTION

Receiving Frequency Range..... 522 kHz — 1,611 kHz
Usable Sensitivity..... 58dB/m
Distortion 0.5%
Signal to Noise Ratio 50 dB
Output Level/Impedance 210 mV/2K Ω

GENERAL

Dimensions 17-1/4" (W) x 2-15/32" (H) x 12-7/32"
438mm(W) x 63mm(H) x 310mm(D)

Weight:

Net 14-15/16 lbs. (4.5 kg)

Design and specifications subject to change without notice.



Division of Alpine Electronics of America, Inc.

19145 Gramercy Place
Torrance, California 90501
(800) 4-LUXMAN

68P83132F29-
Printed in Jap
